



D-ONE[®]
DIVINGHELMET

DRASS[®]

TRADITION INNOVATION EXPERTISE

With over a century of tradition, DRASS Galeazzi is one of the early pioneers of Italian subsea innovation and continues to this day a renowned leader in state-of-the-art technology for the commercial diving and defence sectors.

Continuously active since the 1920s, DRASS founder Roberto Galeazzi made breakthroughs in nautical engineering with his 1926 spherical structures patent. The build of ultra-lightweight structures with an additional 40% pressure resistance was now possible, transforming the future of subsea technology and exploration.

A revolutionary range of Galeazzi-patented technology for manned underwater operations soon followed and a series of world records were established including a manned descent to 275 meters in 1930 - over twice the depth that any human had previously reached. The



Butoscopic Turret became indispensable to navies and for marine research expeditions and the filming of the first deep-sea marine documentaries.

On the heels of this success, the Galeazzi business line unveiled the legendary Galeazzi Atmospheric Diving Suit with its spherical joints (1930 Galeazzi patent). Providing greater agility on the job and enhanced pressure resistance at unprecedented depths, it became the go-to for commercial diving and military application. Galeazzi-inspired suits remain a highly relevant submersible, and their operation continues to this day.



Then, in 1938, the Galeazzi Diving Helmet was launched. Famed to this day for its exquisite workmanship, it soon took the international market by storm.



From the 1940s, the Galeazzi "Marina" helmet became its most popular helmet, and a customized range was exclusively supplied to the Italian Navy Special Forces.



In 1950, the patented PBG Galeazzi helmet went one step further by incorporating an innovative mixed gas demand regulator.



production in the commercial diving industry with classification society certification.

The Galeazzi helmet remains a highly sought-after collector's item to this day.

Today, DRASS 100 Saturation Diving System Series is integrated into the majority of diving vessels and operated by most main diving contractor companies worldwide.

It is the only comprehensive solution of industrialized equipment of serial



DRASS 100 Series incorporates standardized modular equipment for easy configurability and fast-tracked vessel installation as well as specialized technical software, such as fail-safe automation, for complete remote management.

To this day, DRASS continues to drive innovation and efficiency with quality diving solutions for a deeper and safer subsea experience.

Bringing the typical diving helmet firmly into the 21st century, DRASS now introduce the most revolutionary diving helmet to enter the market: DRASS D-ONE. Discover on the following pages why DRASS D-ONE is making waves.

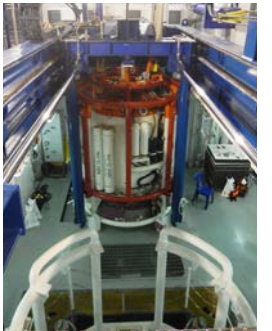

DESIGN METHODOLOGY ORIGINALITY

Perceiving the need to update the design of the standard commercial diving helmet which had remained conventional and unchallenged for so long, DRASS raised the bar once again and **D-ONE Diving Helmet** was born.

To meet the needs of today's diver with today's technology, it was evident that a total helmet overhaul was required. D-ONE incorporates the latest cutting-edge technology for increased safety, ergonomics, and functionality.

The originality of D-ONE goes one leap further: Its 3-in-1 modularity allows the same shell to be used in varying dive environments thanks to interchangeable pods that support a full spectrum of diving activities.

Our D-ONE design team made up of engineers and commercial diving professionals formed the bedrock of a dynamic methodology driving innovation forward and bringing a wealth of expertise to each detail of every designed and manufactured part. The result is a masterpiece in terms of aesthetics, ergonomics, technicality, and functionality.

Using the latest in-house precision machinery and advanced production quality, a stunning redesign was possible, beautifully showcasing our tradition in Italian design and affording the highest level of safety to our divers.

D-ONE has been tested for air use up to -50 msw as per "European Standard EN 15333-1" of January

2008, "Respiratory equipment - Open-circuit umbilical supplied compressed gas diving apparatus - Part 1: Demand apparatus" and EU Directive "EU 2016/425" that substitutes "EU 89/686/EEC".

RECOGNITION



June 2022 - D-ONE awarded the esteemed Menzione d'Onore (Honourable Mention) from ADI - Italian Association of the Industrial Design. D-ONE was chosen by the ADI panel of judges that assessed 500 products from the last 3 years of design projects.



October 2021 - D-ONE selected to showcase the very best of Italian technology and innovation at the G20 World Summit of Heads of State and Government held in Rome.



June 2020 - D-ONE shortlisted by ADI (Italian Association of Industrial Design) from hundreds of design entries during the prestigious ADI Design Index 2020.



September 2019 - D-ONE launch at Offshore Europe exhibition created a buzz in the oil and gas industry amongst commercial diving professionals and provided an opportunity to get hands-on with the most advanced diving helmet on the market.



MODULARITY

VERSATILE COST-EFFECTIVE CONFIGURABLE

D-ONE has been designed around the concept of modularity: One helmet shell to suit varying dive environments by means of interchangeable pods:

- Standard Pod for Air Diving
- PLUS Pod for Air Diving in Contaminated Waters
- Rebreather Pod for Saturation Diving

STANDARD POD FOR AIR DIVING

D-ONE is supplied with a standard pod for air diving activities. It is easily removed and interchangeable with alternative pods for more specialized diving requirements.

PLUS POD FOR DIVING IN POLLUTED WATERS

For diving in contaminated waters, the helmet can be configured with a reclaim valve that prevents contact of the valve with polluted water. Coupled with a dry-suit and water shroud, the diver is effectively sealed off and protected from the surrounding environment.

REBREATHER POD FOR SATURATION DIVING

D-ONE will soon be configurable with a dedicated pod to support the installation of a Rebreather system in accordance with the most stringent commercial diving requirements of the North Sea and Norwegian oil and gas sector.



BUY NOW

WWW.D-ONE.TECH

SMOOTH BREATHING

ROBUST OPTIMIZED PRECISION

D-ONE helmet shell is made entirely of stainless steel 316L, and CNC machined for a long-lasting product of the highest quality.

Polyurethane gaskets seal the Balanced Demand Regulator Pod and the viewport lens due to the excellent durability of polyurethane in the saline environment.

Weight:	~ 16 Kg
Porthole:	Polycarbonate 3.1
Side Block:	Stainless Steel
Hardware:	Stainless Steel/Chromed Brass
Control knobs:	Polyurethane
Neck Dam:	Neoprene/Polyurethane
Neck Dam O-Ring:	NBR
Head Cushion:	Nylon
Umbilical dimensions:	Minimum diameter 3/8" (9,5mm) of maximum length of 180 m

"BAFFO" EXHAUST SYSTEM

Drass-patented Baffo (Italian for "moustache") is an optimized exhaust system that works in synergy with the Balanced Demand Regulator to reduce exhalation effort, for a smooth breathing experience.

BALANCED DEMAND REGULATOR

Engineered to minimize inhalation effort while maximizing breathable air volume, the Balanced Demand Regulator is part of an interchangeable pod, providing full versatility to any helmet configuration.

D-ONE's balanced demand regulator ensures comfortable breathing at all operational depths from 0 to 50 msw with air gas supply up to 18 bar, eliminating the need for gas delivery adjustments, with its performance verified and certified by an independent, certified body.

The regulator's innovative mechanical design maintains perfect pressure balance between the air inside the helmet and the water outside, responding precisely to any pressure change, automatically equalizing by injecting gas and expelling water instantly.

Made entirely of stainless steel and precision-machined to the tightest tolerances, the regulator achieves outstanding Respiratory Minute Volume (RMV) and Work of Breathing (WOB) values, far exceeding the minimum requirements, ensuring effortless breathing at any depth.



INTUITIVE ERGONOMICS COMFORT

Ergonomically engineered for maximum comfort and safety, D-ONE puts the well-being of divers first.

VISION

Having an unhindered visual is a fundamental requirement on the job. D-ONE strategically places the face closer to the viewport for a far wider field of vision than is found on contemporary helmets across the market. This intelligent design offers increased peripheral vision for enhanced personal safety and a general sense of comfort in every situation.

REAR ANGLE

The 30° rear-angled design (Patent Pending) offers a natural, full range of motion on the job with unrestricted neck movement. This avoids pressure to the back of the neck when looking upwards and on prolonged dives, as well as during donning and removal of the helmet. Gone are the days of classic neck fatigue and repetitive strain injury.

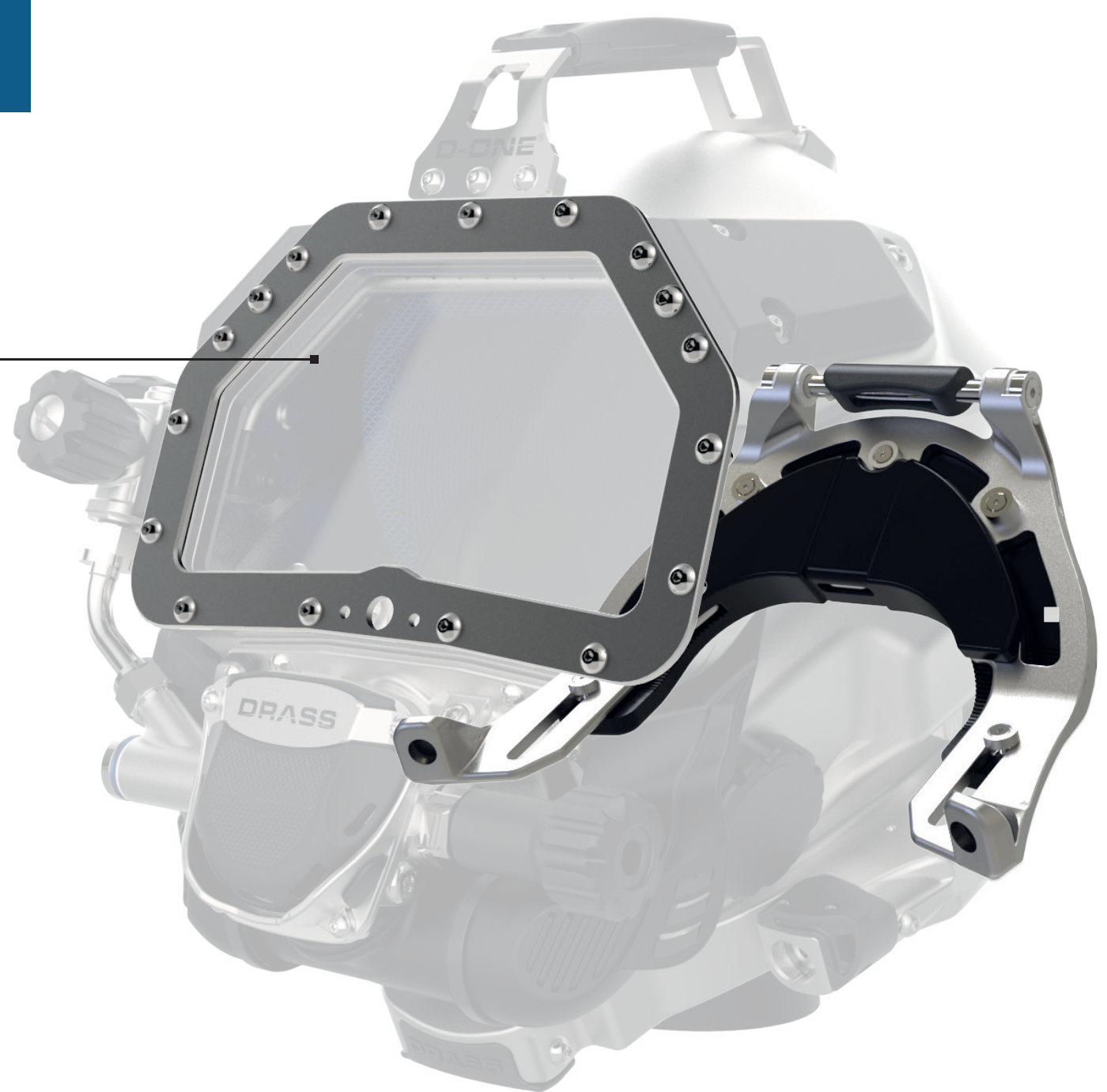
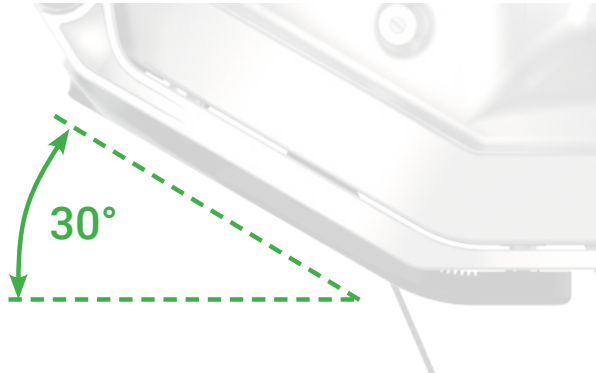
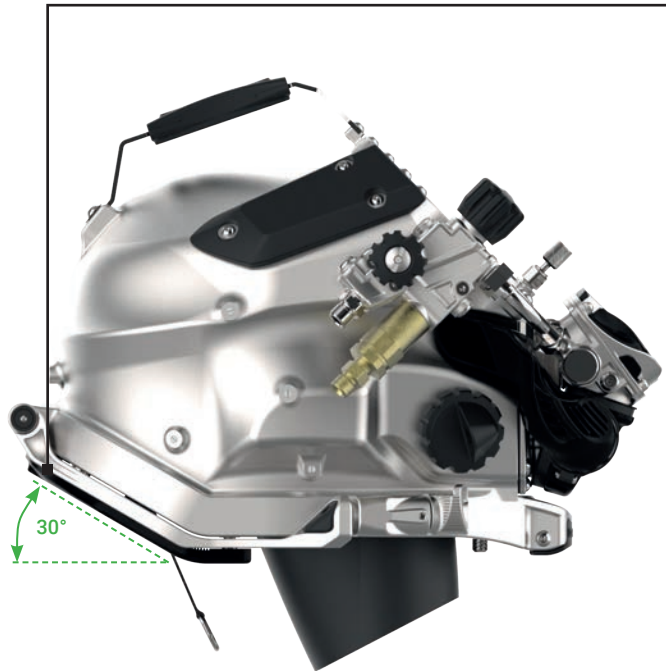

PLUS POD

AIR-TIGHT WATER-SEALED PROTECTION

Interchangeable with D-ONE AIR Pod, D-ONE PLUS Pod is specifically designed to protect divers in dirty water and is certified according to EN 15333-1.

When the PLUS Pod is installed on the D-ONE helmet, the diver can choose to operate in either surface-vent mode or open-circuit mode.

D-ONE PLUS allows the highest achievable grade for diving in contaminated waters, in compliance with NAVSEA guidance for diving in CAT-1 grossly contaminated waters. It can be supplied with the appropriate drysuit for a sealed connection and integration with a surface-supplied and vented system, preventing diver exposure to external contaminants.

All physical characteristics and process connections of D-ONE PLUS ensure full compatibility with a diver's existing closed-circuit diving system.

Made entirely of stainless steel 316L, D-ONE diving helmet can withstand the most common decontamination processes with extreme resistance to chemical agents and high-temperature sterilization systems.



BUY NOW

WWW.D-ONE.TECH

PATENTED GAS RECLAIM SYNERGY

D-ONE PLUS Pod comes with an innovatively designed and patented Gas Reclaim Valve and Flow Disc.

Its Gas Reclaim Valve is designed for best performance across various depths and provides the perfect synergy of two critical elements, namely the volume of the valve and the shape of the Flow Disc.



Its lightweight and durable Flow Disc, crafted in titanium, guarantees smooth breathing effort and optimized gas recovery at any depth on every dive thanks to its precision-engineered gas-flow vents.

Located in a mirror position at the same height, the Reclaim Isolation Ball-Valve and Emergency Valve are intuitively positioned for easy reach. High-quality materials and ease of maintenance ensure a very long valve life. All supplied parts can be easily accessed using ordinary maintenance tools.

No more than 15 minutes is required for valve maintenance. With the simplicity of valve disassembly and access to inner valve areas, dirt or obstructions can be easily removed.

The sum of these fine details renders the D-ONE, and its associated pods, uniquely efficient and user-friendly.

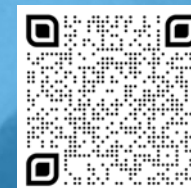
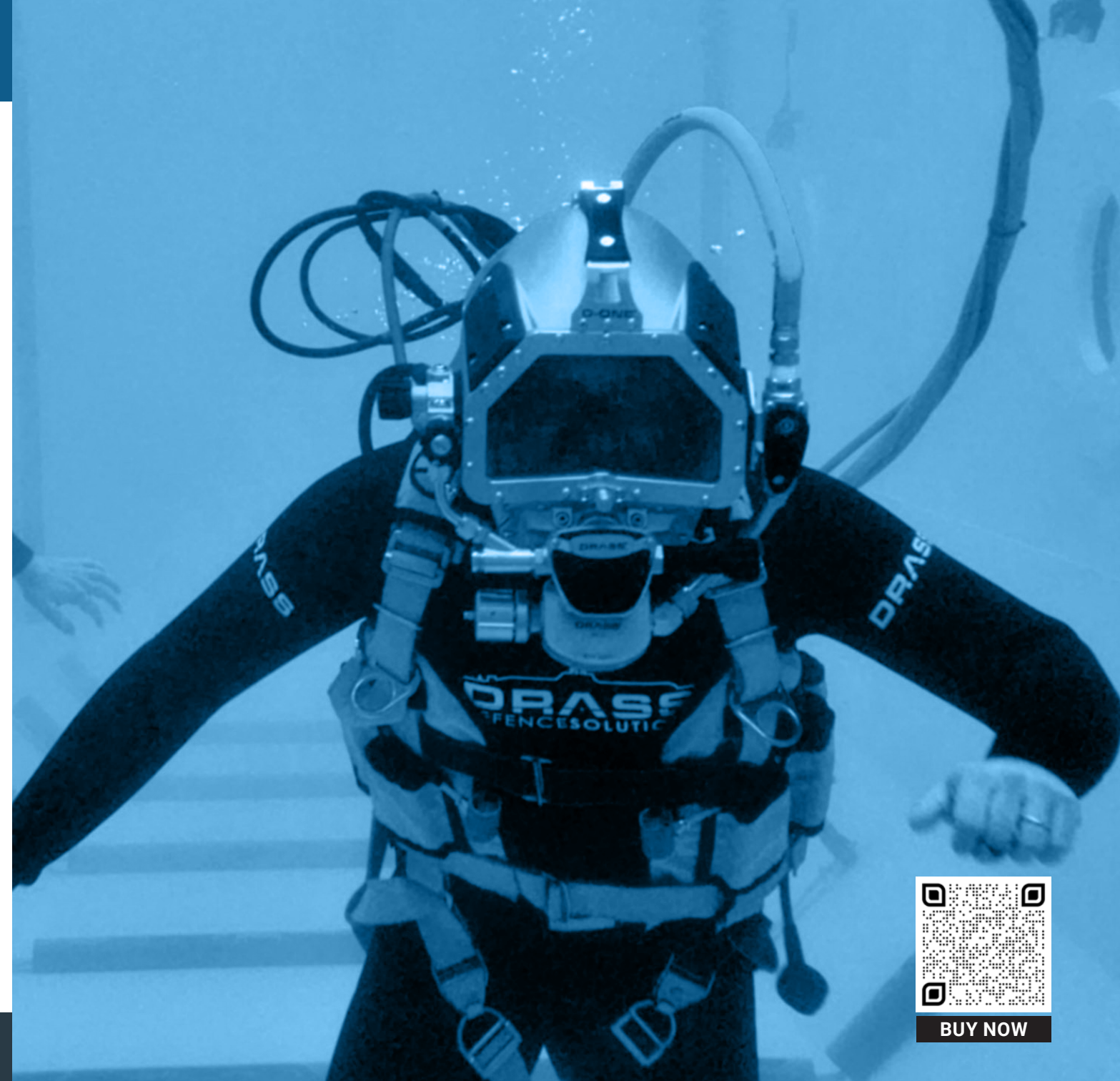

[BUY NOW](#)

D-ONE[®]
AIR



D-ONE[®]
PLUS



INTEGRATED SYSTEM COMPONENTS

D-ONE is designed with integrated light and video camera options as well as a LIFE-TRACKER Module that enables the remote monitoring of ongoing underwater activities.

These components can be installed using standard commercial systems or taking advantage of the helmet's dedicated pod and cable-routing system for enhanced safety.

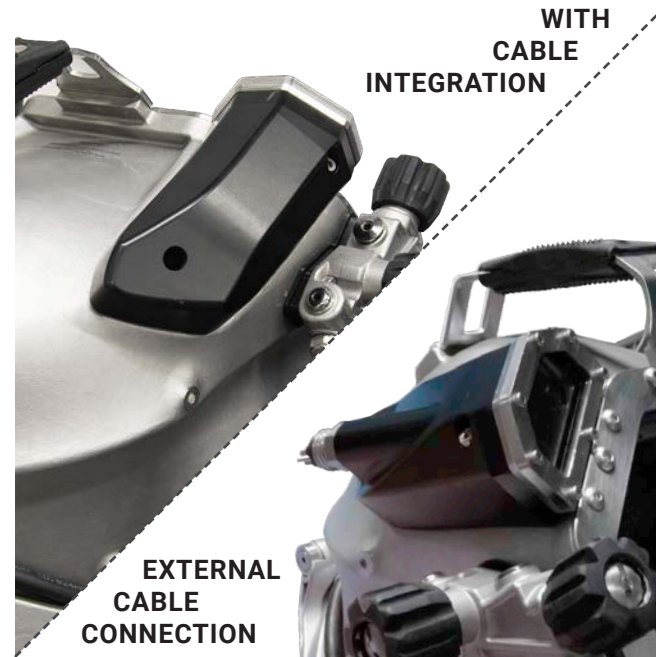

MONITORING

VIDEOCAMERA AND LIGHT

By simply removing the two polyurethane lateral plates that act as bumpers, the dedicated video camera and light can be installed.

Alternatively, a diver's own video camera and light can be attached by means of the supporting brackets.

When the dedicated DRASS video camera and light are chosen, these work in synchronization with the in-built LIFE-TRACKER system for diver monitoring from topside.

LIGHT CONNECTOR PIN OUT

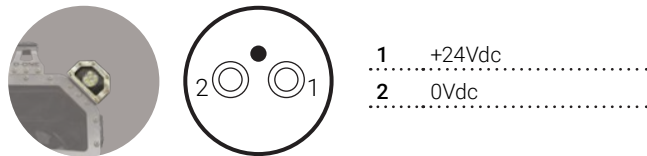

CAMERA CONNECTOR PIN OUT

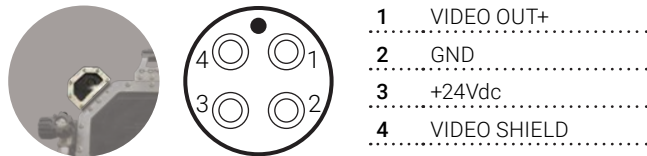

BUY NOW

D-ONE HELMET LIFE-TRACKER

D-ONE LIFE-TRACKER is an advanced smart device that incorporates a digital viewport displaying real-time visual updates from the dive control unit.

Strategically positioned sensors integrated within the D-ONE helmet enable the remote tracking of operational parameters and diver vitals, for enhanced diver operational safety and full peace of mind on the job.



LIFE-TRACKER

D-ONE LIFE-TRACKER monitors:

- Breathing Pattern (Respiratory Rate): 0-90 breaths p/m
- Diver Suit Temperature: -10°C to +80°C
- Diver Helmet Internal Temperature: -10°C to +80°C
- Bail-Out Pressure: 0-300 bar
- Dive Duration Timer
- Depth: 0-100 bar
- Orientation and Inclination:
 - Accelerometer, SFR: 16 G
 - Magnetometer, SFR: +/- 8 G
 - Roll/Pitch: 0,5 deg
 - Yaw/Heading: 2 deg
 - Gyroscope: Full range: 2000 deg/s

All data is seamlessly transmitted via the diver's umbilical to the diving supervisor at surface level for 360° situational awareness.

In addition, its associated software supports the monitoring of multiple divers, keeping them in the loop with optimized dive team coordination and safety alerts, as well as comprehensive data analysis topside.

A handy cable connection at the rear of the helmet's exterior utilizes existing cable pathways meaning that no helmet modification is necessary during installation.

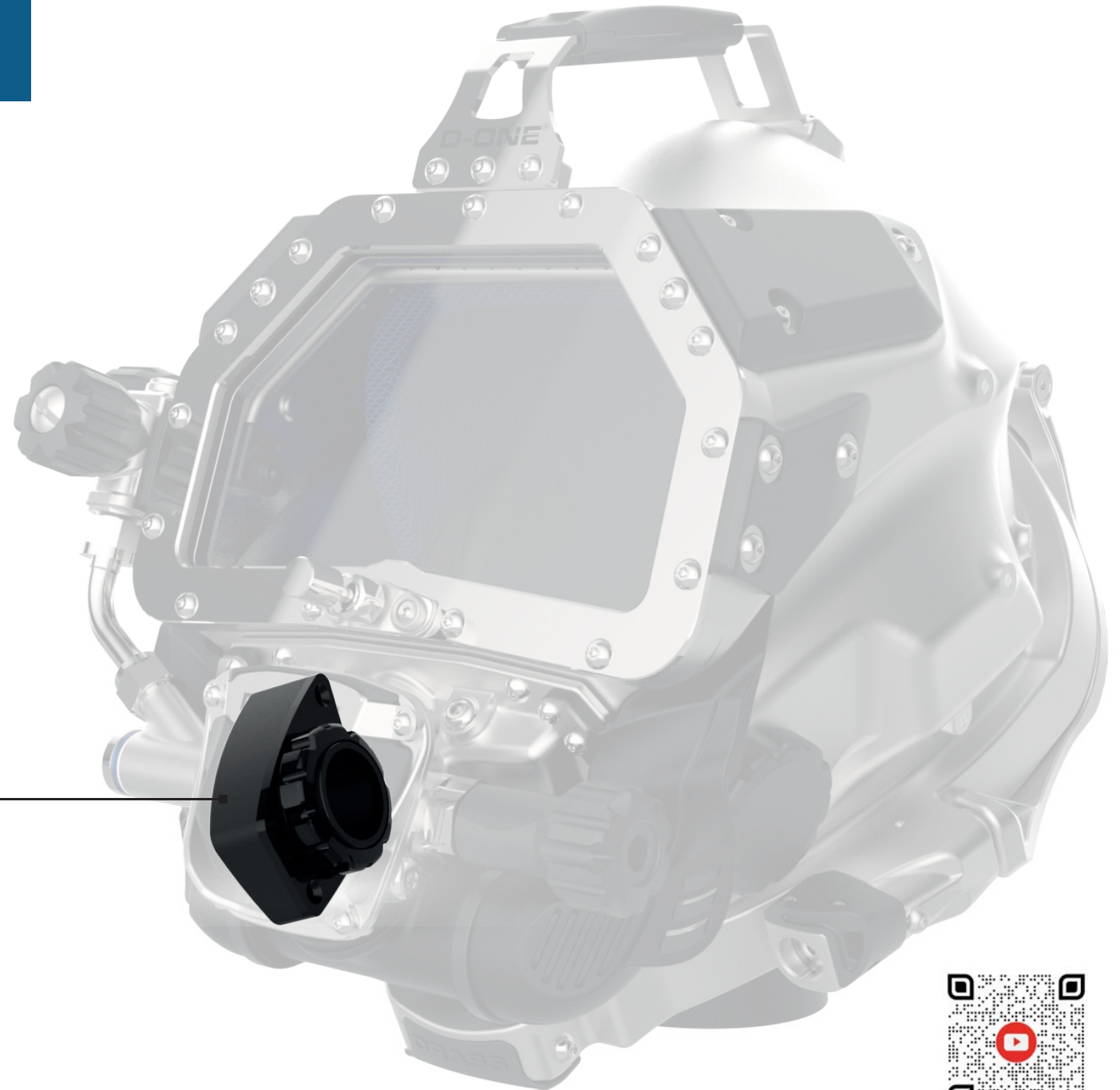

CUSTOMIZE YOUR D-ONE

Aside from the video and light setup, D-ONE can also be equipped with dedicated accessories for specific activities while still retaining its overall shape and dimension.

Dedicated D-ONE accessories include:

- Welding shield
- Hot water shroud
- Defogger

WELDING SHIELD

For welding or oxy-arc cutting activities, a dedicated shield for eye protection can be added. The same screws that affix the helmet's viewport are used for the installation of the optional welding shield.

WATER SHROUD

Whilst a water temperature range of 4°C to 34°C is assured for helmet certification, the installation of a water shroud enables dives at lower temperatures.

Temperature resistance parameters are provided on the last page. During sand blasting or diving in contaminated waters, a water shroud isolates the helmet from the

DEFOGGER

The intelligent design of D-ONE's defogger system means that there is not the typical high-pitched whistling noise when flushing out the helmet.

The free-flow of air into the helmet is practically silent, delivering total comfort and perfect audio communications.

The defogger is a secondary lens that, by means of a dedicated frame, is easily installed on the outer side of the viewport. Connected to the hot water supply, water flows between both lenses preventing the build-up of fog inside the helmet.



[BUY NOW](#)

ANTI-FLOOD FAIL-SAFE TECHNOLOGY

D-ONE fail-safe technology ensures a secure positioning and water-tight seal thanks to its Double-Action Pull-Pin Latching System and an Interlocking Swing-Arm Chin Retainer.

DOUBLE-ACTION PULL-PIN SYSTEM

Rather than adopting the typical single locking mechanism that actuates with a single movement, D-ONE's locking collar incorporates a double-action pull-pin latching system so that no accidental motion can cause an instant flooding of the helmet.

INTERLOCKING SWING-ARM CHIN RETAINER

This safety system requires both swing-arms to interlock for a secure fit on the diver's head. Indeed, the collar cannot close unless the swing-arms are correctly in position, thereby avoiding any misstep.

Working in conjunction with the neck pad and chin strap, it prevents the helmet from slipping off and floating upwards due to upthrust which would lead to flooding and/or drowning.

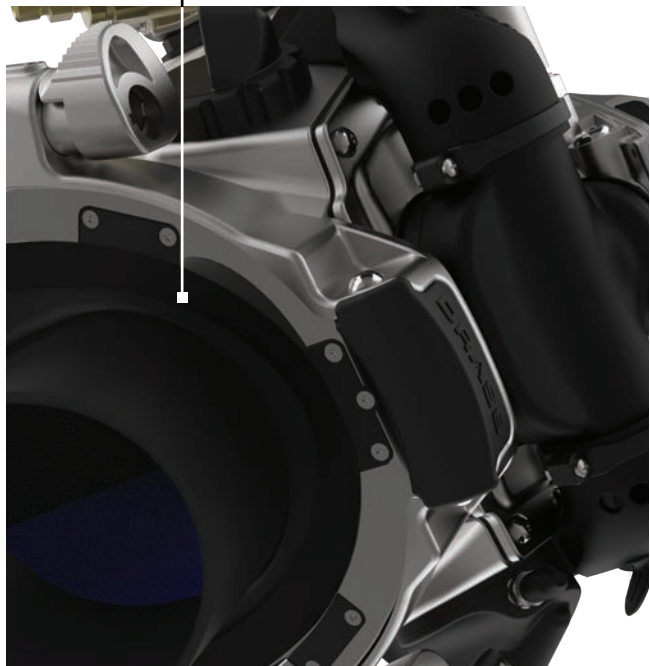

SIMPLIFIED USER-FRIENDLY MAINTENANCE

Whilst D-ONE servicing and spare parts replacement is completed by a dive technician, a diver should be familiar enough with his helmet to perform routine maintenance for its basic upkeep.

To this end, DRASS has optimized the design of D-ONE spare parts allowing a simplified approach to maintenance.

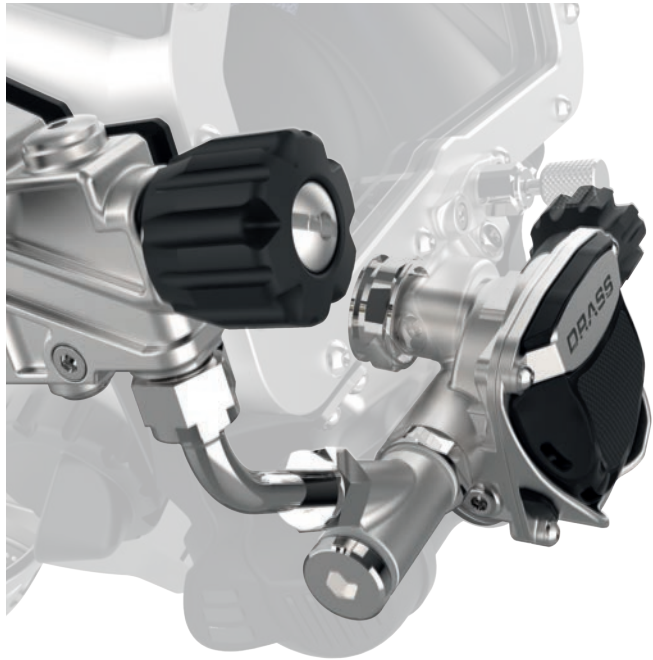

SIDE-BLOCK ASSEMBLY

Installation and removal of the side-block for maintenance takes place easily thanks to its design which properly seals with the helmet by means of O-rings, rendering silicone sealant a thing of the past.

The helmet is immediately ready for use with no time wasted on sealant curing - a process that typically takes 24 hrs.

NECK-DAM INSTALLATION

Neck-dam replacement is performed by simply removing the collar over the stepped ring and placing the new neck-dam into position while engaging the front and rear alignment notches. The O-ring shaped neck-dam rim mates perfectly with the machined groove of the stepped ring.

Once in position, the respective screws are secured and the helmet is ready to go. No more struggling with neoprene positioning and no drilling required.

BALANCED DEMAND REGULATOR SETTING

Setting the Balanced Demand Regulator is a simple process with the designated key.

All regulator parts remain securely in position whilst a dedicated plug is removed to insert the pressure adjustment key (included with D-ONE). The regulator can then be set to the correct pressure value in no time at all.

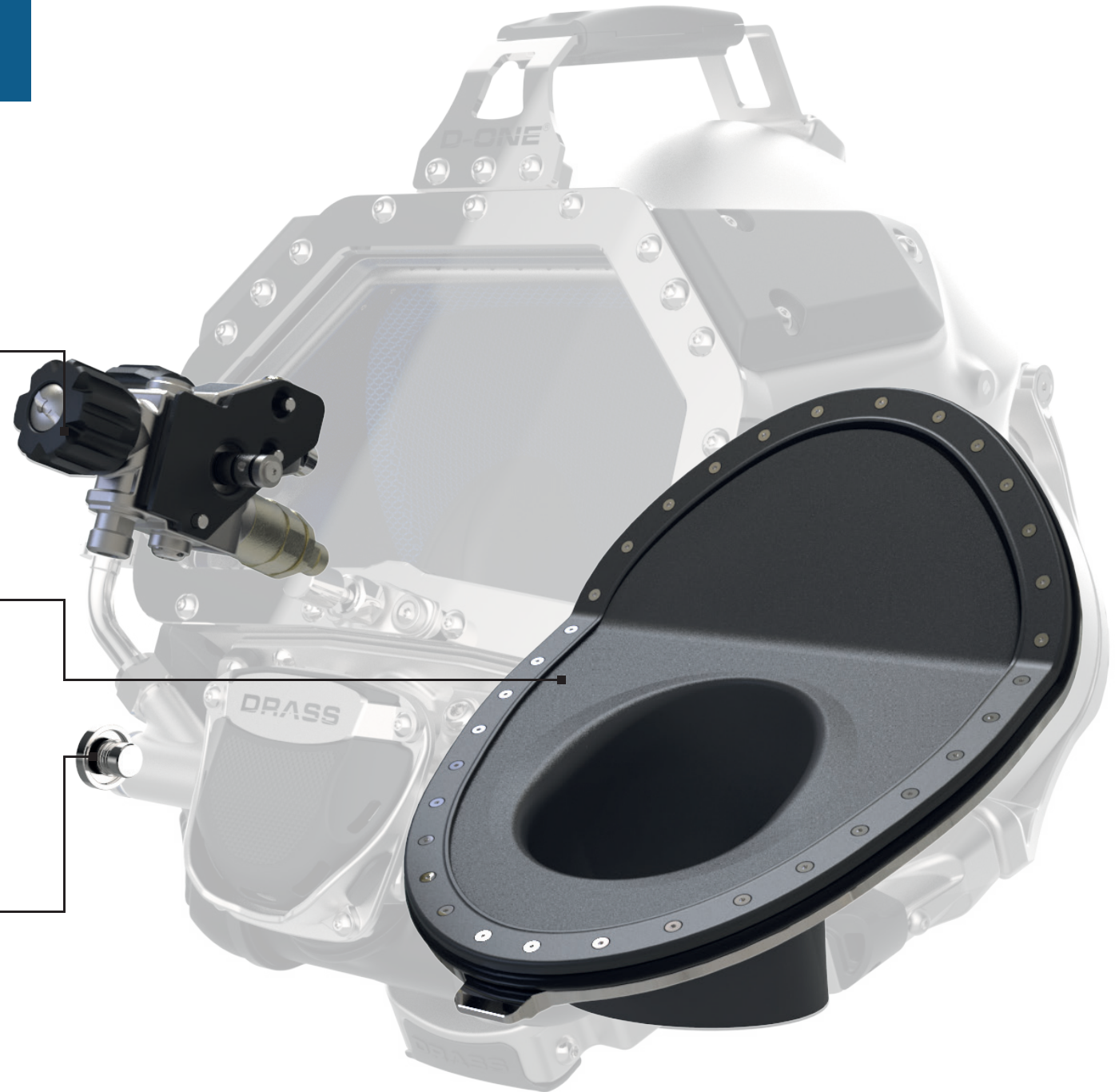

CUSTOMIZATION

COMING SOON



D-ONE
REBREATHER

REBREATHER POD



WELDING SHIELD



D-ONE
AIR



WATER SHROUD



D-ONE
PLUS



PLUS POD

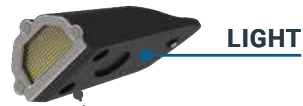

LIGHT



VIDEOCAMERA

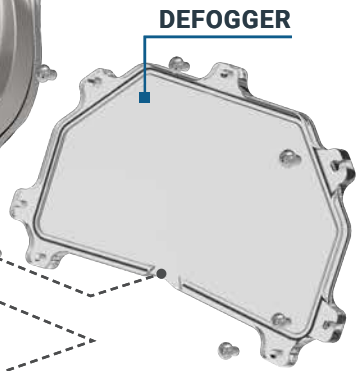

DEFOGGER

STANDARD
AIR DIVING POD

YOUR D-ONE HELMET, UNIQUE TO YOU!

For a truly customized diving experience, select the most suitable standard configuration adding the dedicated accessories to don your D-ONE and dive right it!

WWW.D-ONE.TECH



BUY NOW

QUALITY CONFORMITY PERFORMANCE

CE stands for "Conformité Européene" and refers to European Conformity. A mandatory requirement for the issue of the CE marking and the associated selling of the respective product in the European Economic Area is the EU Declaration of Conformity.

With this declaration, manufacturer DRASS confirms that D-ONE complies with the highest health, safety, quality, and environmental protection standards of all the relevant European directives in accordance with European Regulation (EU) 2016/425, as Personal Protective Equipment (PPE) Category III, and in accordance with EN15333-1 technical standards.

In addition to EN15333-1:2008 helmet certification, D-ONE has obtained Class A certification on Impact Protection, guaranteeing maximum safety and comfort for users.

This designated CE marking guarantees that DRASS D-ONE has passed the certification process following rigorous product quality and production process audits, as well as an extensive series of stringent performance tests.

All testing was overseen and attested to by a third-party notification body at DRASS Life Support Equipment Test Facility, the most advanced laboratory of its kind for the testing of underwater technology in accordance with European Standards and Norwegian regulations.

CERTIFICATION

TEST PROGRAMME



EN 15333

BREATHING SYSTEM

Breathing performance	Volume weighted average inhaled CO ₂
Upstream demand valve	Exhalation valve
Downstream demand valve	Hydrostatic imbalance

FACEPIECE

Mechanical strength of connections between facepiece and connector	Noise Assessment
Visor Impact Resistance	Field of vision
Head protection	Sea Water Resistance

TEMPERATURE RESISTANCE

-20°C / +50°C conditioning -20°C and performance +50°C and performance
-30°C / +70°C conditioning -30°C and performance +70°C and performance
Cold Water Testing

GENERIC

Cleaning and Disinfection
Oxygen Pressure Surge Test
Practical Performance

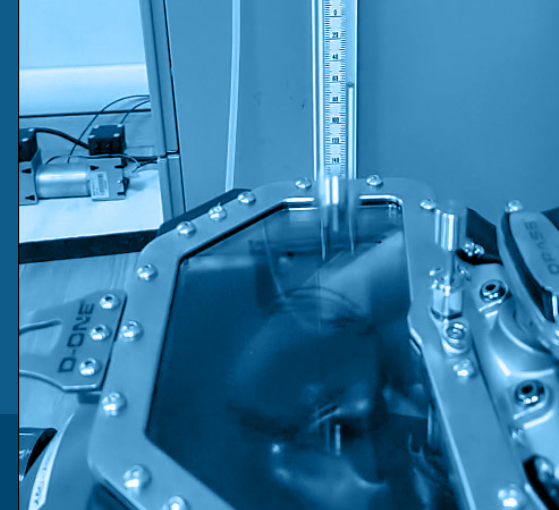

100
YEARS

FROM TRADITION TO TECHNOLOGY

Continuously active since 1927 with the Galeazzi business line, Drass has extensive experience in manned underwater technology, establishing the world record for deep diving immersion with an atmospheric diving suit in 1937.

The company is now an international leader in commercial diving, medical hyperbaric, midget and compact submarines and vehicles for special forces.



DRASS®

Drass Galeazzi s.r.l.u.
Headquarters: Via T. Mattei, 4
57121 Livorno – Italy

Phone +39 0586 421221 - Fax +39 0586 421223

email: info@d-one.tech • www.d-one.tech